

NP50 Block Diagram

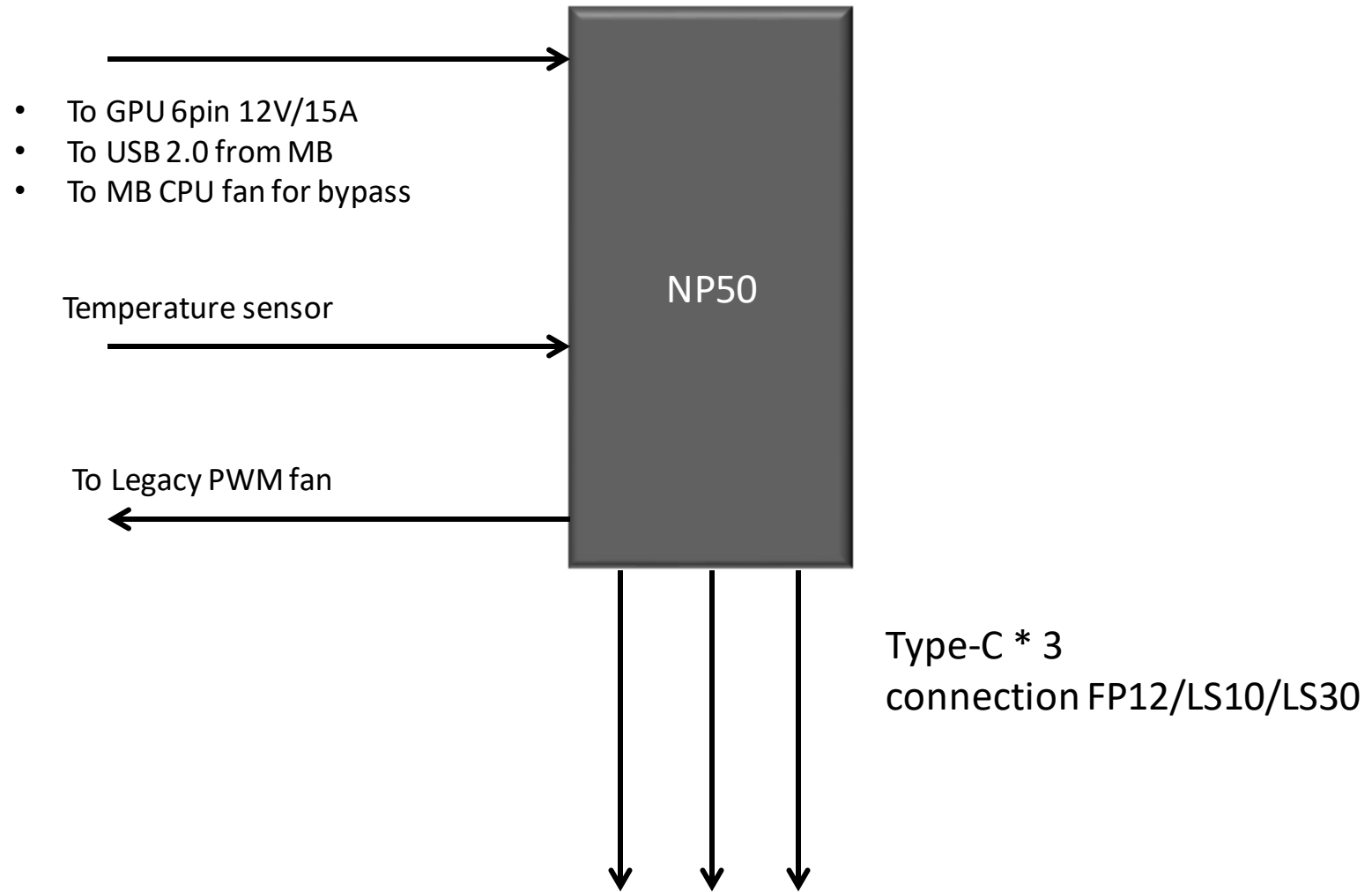

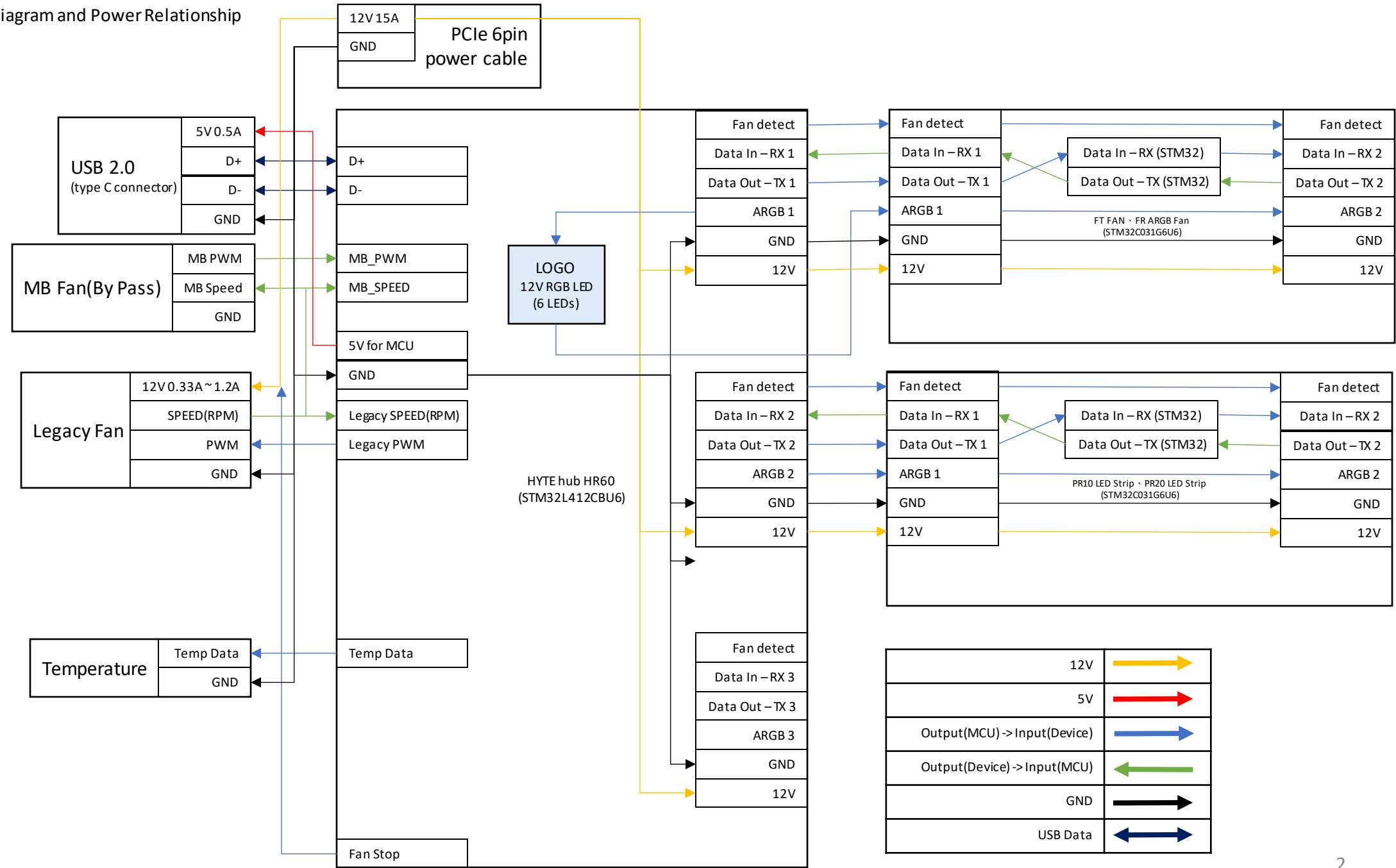

Type C Connector

HyteBus 24PIN Define

Type-C(24PIN) male

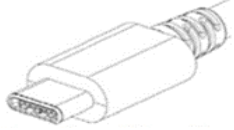

(power output)

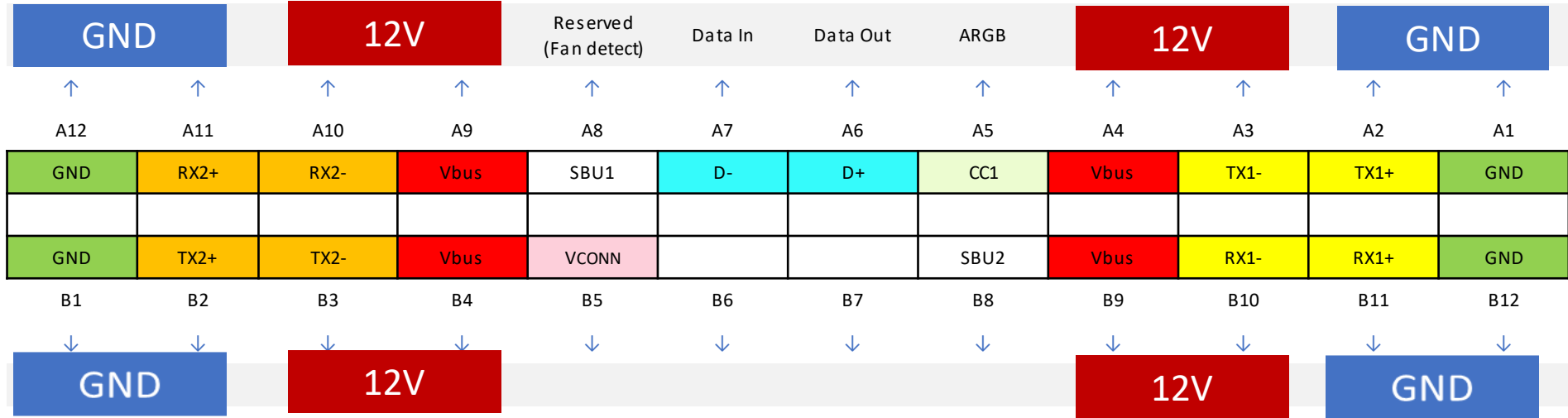

Type-C(24PIN) female



(power Input)

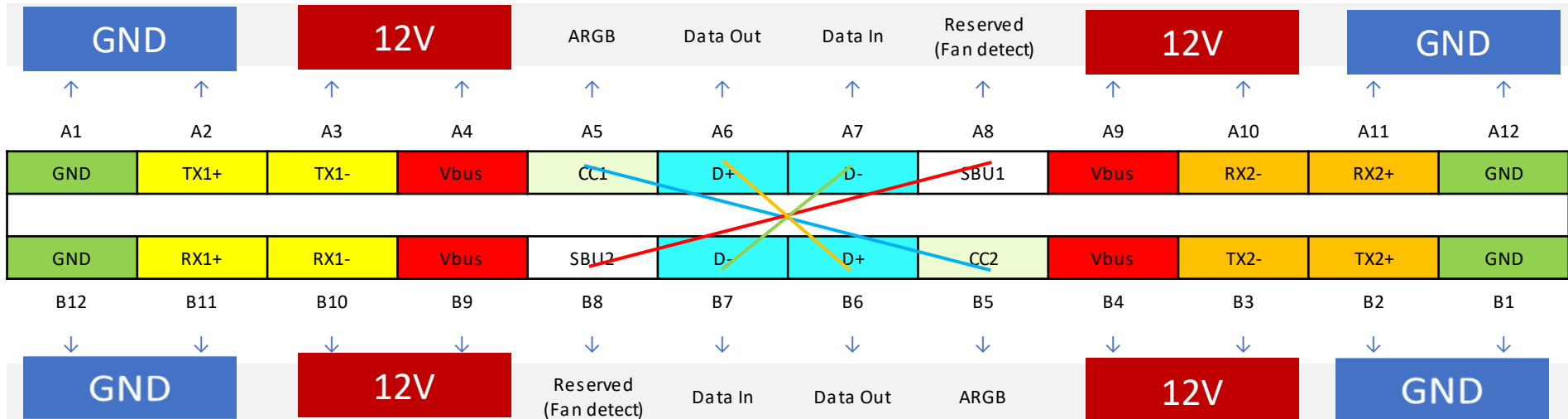

NP50 Power Connector Define & Signal Connector Define

Power connector TYPE C x2 provides 12V 21pin and GND 22pin total 15A. USB 5V 1pin 0.5A

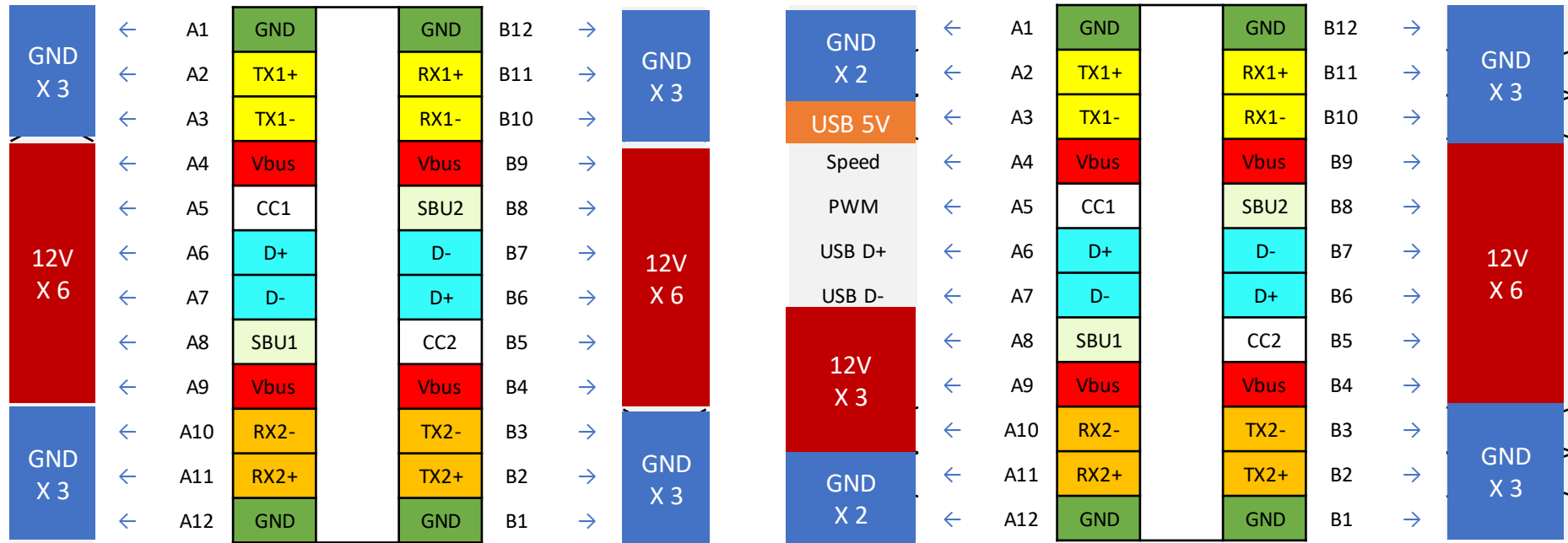

Power connector define use 24PIN male

Power + Signal connector define use Type-C 24PIN male

